

STANDARD EQUIPMENT

- AIR CLEANERS** – Dry type with rain shield and service indicators.
- BARRING DEVICE** – Manual.
- BEARINGS** – Heavy duty, replaceable, precision type.
- BREATHER** – Closed system.
- CONNECTING RODS** – Forged steel, rifle drilled.
- COOLING SYSTEM** – Choice of heat exchanger with expansion tank, or connection for remote radiator cooling. (One shutdown level switch for each circuit included on heat exchange units).
- CRANKCASE** – Integral crankcase and cylinder frame.
- CRANKSHAFT** – Counterweighted, forged steel, hardened journals, dynamically balanced, with sealed viscous vibration damper.
- CYLINDER HEADS** – Interchangeable valve-in-head type. Two hard faced intake and two hard faced inconel exhaust valves per cylinder. Hard faced intake and exhaust valve seat inserts.
- CYLINDERS** – 9.375" (238 mm) bore x 8.5" (216 mm) stroke. Removable wet cylinder liners. Number of cylinders – Sixteen.
- ENGINEATOR BASE** – Engine, generator and heat exchanger (if specified) are mounted and aligned on a welded steel, wide flange base, designed for solid mounting on an inertia block, with standard base lifting eyes.
- ENGINE PROTECTION SHUTDOWN CONTACTS** – For high water temperature, low oil pressure, high intake manifold temperature (GSI units only) and overspeed (electronic speed switch – shipped loose). Use in conjunction with a DC control panel for unit shutdown, (reference Engomatic® controls). Note: DC shutdown control panel is not supplied as standard.
- EXHAUST SYSTEM** – Water cooled exhaust manifold with single vertical exhaust at center. Flexible stainless steel exhaust connection 8 (203 mm) long with 14 (356 mm) flange on GSI.
- FUEL SYSTEM** – Two natural gas 4 downdraft carburetors, two Mooney Flowgrid 250 gas regulators, one 2" NPT flexible connection (shipped loose), and one 2" NPT Magnatrol gas solenoid valve (shipped loose). Fuel pressure – 30 PSIG minimum and 50 PSIG maximum. (207-414 kPa).
- GENERATOR** – Open, dripproof, direct connected, fan cooled, 2/3 pitch, A.C. revolving field type, two bearing generator with flexible coupling, brushless exciter, short circuit sustain (PMG type maintains 270% of rated generator current for up to 10 seconds on 105° C temperature rise generators; maintains 250% of current on 130° C rise generators) and damper windings. TIF and Deviation Factor within NEMA MG-1.32. Voltage 480/277, 3 phase, 4 wire, Wye 60 Hz and 400/230, 3 phase, 4 wire, Wye 50 Hz. Other voltages are available, consult factory. Insulation material NEMA Class F. Temperature rise within NEMA (105° C) for continuous power duty, within NEMA (130° C) for standby duty. All generators are rated at 0.8 Power Factor. Includes space heater, 115/230 V, 1 phase.
- GOVERNOR** – Woodward Model EG10P electric actuator (mounted), magnetic pickup (mounted) and a separate electric governor control, Woodward Model 2301D (shipped loose).
- IGNITION** – Waukesha Custom Engine Control® Ignition Module. Electronic digital ignition system.
- INSTRUMENT PANEL** – Engine mounted, includes water temperature, oil temperature, oil pressure, intake manifold temperature, and intake manifold pressure-vacuum gauge. All temperature sensors have thermowells. Two engine mounted run-stop push buttons are supplied. Recommend optional Model 4000 free standing panel for continuous power installations.
- INTERCOOLER** – Air to water.
- JUNCTION BOXES** – Separate AC, DC and instrument/ thermocouple junction boxes for engine wiring and external connections.
- LUBRICATION** – Full pressure, positive displacement pump. Full flow oil filter (shipped loose) and flexible connections (shipped loose). 50 or 60 Hz, 230 volt AC, single phase electric motor driven intermittent prelube pump with motor starter (other voltages can be specified). Note: External control logic required to start/ stop prelube pump.
- OIL COOLER** – Shell and tube type (mounted).
- OIL PAN** – Cast alloy iron base type with removable doors.
- PAINT** – Oilfield Orange.
- PISTONS** – Aluminum with floating pin. Oil cooled.
- STARTING EQUIPMENT** – One air starter with strainer and lubricator. Includes 24 VDC solenoid valve for remote start provision and crank termination switch (shipped loose).
- TURBOCHARGERS** – Two with water cooled bearing housings. Wastegate controlled.
- VOLTAGE REGULATOR** (shipped loose) – SCR static automatic type providing 1% regulation from no load to full load, three phase sensing and automatic subsynchronous speed protection. Includes voltage adjustment rheostat (shipped loose).
- WATER CIRCULATING SYSTEM, AUXILIARY CIRCUIT** – Belt driven water circulating high capacity pump for intercooler and lube oil cooler. See S6535-14 performance curve for use with standard 10" diameter crankshaft pulley.
- WATER CIRCULATING SYSTEM, ENGINE JACKET** – Belt driven water pump, 175 – 180° F (79 – 82° C) thermostatic temperature regulation full flow bypass. Single ANSI flange connections for inlet and outlet on water connect units.

**VHP® Series Gas
Enginator® Generating
System**

1175 - 1750 kW

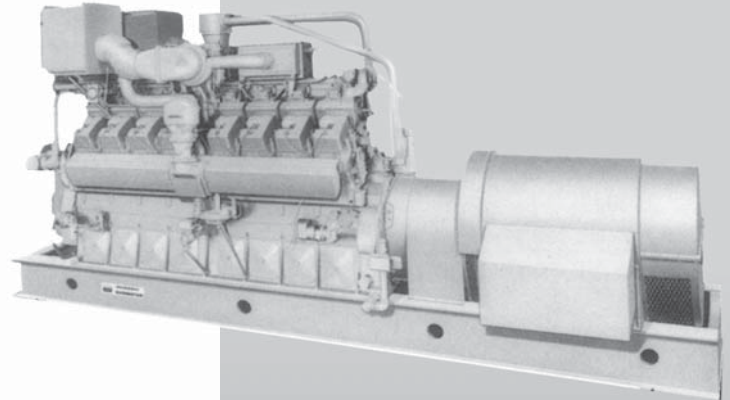

Enginator shown with options.

Model VHP9500GSI

Turbocharged and Intercooled
Gas Fueled Enginator

SPECIFICATIONS

Waukesha Engine P9390GSI, Four Cycle, Overhead Valve	Jacket Water Capacity 148 gal. (560 L)
Cylinders V 16	Starting System 150 psi air
Piston	Fuel LHV
Displacement 9388 cu. in. (154 L)	900 Btu/ft ³ (33.5 J/cm ³)
Bore & Stroke 9.375" x 8.5" (238 x 216 mm)	Lube Oil Capacity 155 gal. (587 L)
Compression Ratio 8:1	



PERFORMANCE DATA: VHP9500GSI GAS ENGINEATOR GENERATING SYSTEM

HEAT EXCHANGER COOLING Intercooler Water: 85°F (29°C)	CONTINUOUS POWER*		STANDBY POWER	
	1200 rpm 60 Hz	1000 rpm 50 Hz	1200 rpm 60 Hz	1000 rpm 50 Hz
kW RATING	1475	1225	1825	1520
Fuel Consumption x 1000 Btu/h (kW)	17100 (5011)	13615 (3990)	20270 (5941)	16140 (4730)
Jacket Water x 1000 Btu/h (kW)	5295 (1552)	4290 (1257)	6205 (1819)	4905 (1438)
Lube Oil x 1000 Btu/h (kW)	546 (160)	472 (138)	618 (181)	525 (154)
Intercooler x 1000 Btu/h (kW)	458 (134)	315 (92)	581 (170)	404 (118)
Heat Radiated x 1000 Btu/h (kW)	862 (253)	775 (227)	859 (252)	775 (227)
Exhaust Energy** x 1000 Btu/h (kW)	4378 (1283)	3810 (1117)	5920 (1734)	4445 (1303)
Exhaust Flow lb/h (kg/h)	14125 (6406)	11240 (5099)	16930 (7680)	13450 (6101)
Exhaust Temperature °F (°C)	1250 (677)	1188 (642)	1247 (675)	1189 (643)
Induction Air Flow scfm (nm ³ /hr)	3025 (4860)	2410 (3870)	3630 (5830)	2885 (4640)

WATER CONNECTION COOLING Intercooler Water: 130°F (54°C)	CONTINUOUS POWER*		STANDBY POWER	
	1200 rpm 60 Hz	1000 rpm 50 Hz	1200 rpm 60 Hz	1000 rpm 50 Hz
kW RATING	1400	1175	1750	1450
Fuel Consumption x 1000 Btu/h (kW)	16315 (4781)	12985 (3806)	19360 (5674)	15390 (4511)
Jacket Water x 1000 Btu/h (kW)	5075 (1488)	4090 (1199)	5920 (1735)	4760 (1394)
Lube Oil x 1000 Btu/h (kW)	528 (155)	453 (133)	595 (174)	514 (151)
Intercooler x 1000 Btu/h (kW)	321 (94)	190 (56)	466 (136)	273 (80)
Heat Radiated x 1000 Btu/h (kW)	856 (251)	772 (226)	846 (248)	777 (228)
Exhaust Energy** x 1000 Btu/h (kW)	4920 (1442)	3660 (1072)	5665 (1661)	4260 (1248)
Exhaust Flow lb/h (kg/h)	13555 (6148)	10705 (4855)	16320 (7403)	12810 (5810)
Exhaust Temperature °F (°C)	1261 (683)	1188 (642)	1250 (677)	1192 (644)
Induction Air Flow scfm (nm ³ /hr)	2905 (4670)	2295 (3690)	3505 (5630)	2745 (6780)

Typical heat balance data is shown. Consult factory for guaranteed data.

***Continuous Power Rating:** The highest electrical power output of the Enginotor available for an unlimited number of hours per year, less maintenance. It is permissible to operate the Enginotor with up to 10% overload for two hours in each 24 hour period.

Standby Power Rating: This rating applies to those systems used as a secondary source of electrical power. This rating is the electrical power output of the Enginotor (no overload) 24 hours a day, for the duration of the primary power source outage.

Rating Standard: The Waukesha Enginotor power rating descriptions are in accordance to ISO 8528, DIN6271 and BS5514. It is also valid for ISO 3046/1-1986 with an engine mechanical efficiency of 90% and auxiliary water temperature T_{cr}a (clause 10.0) is limited to ± 10° F (5° C).

**Heat rejection based on cooling exhaust gas to 85° F (29° C).

All natural gas engine ratings are based on a fuel of 900 Btu/ft³ (35.3 MJ/nm³) SLHV, with a 91 WKI®. For conditions or fuels other than standard, consult Dresser Waukesha Application Engineering Department.

Consult your local Waukesha Distributor for system application assistance. The manufacturer reserves the right to change or modify without notice, the design or equipment specifications as herein set forth without incurring any obligation either with respect to equipment previously sold or in the process of construction except where otherwise specifically guaranteed by the manufacturer.

Cooling

Equipment	L in (mm)	W in (mm)	H in (mm)	Avg. Wt. lb (kg)
Heat Exchanger	290 (7370)	92 (2340)	130 (3300)	48250 (21040)
Water Connection	265 (6730)	87 (2210)	130 (3300)	46750 (21200)

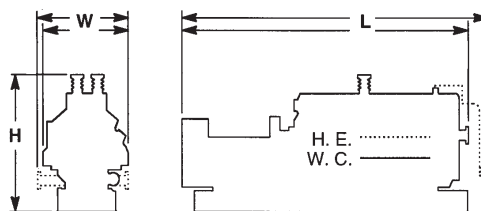

Bulletin 8012 1008

Dresser Waukesha
1101 West St. Paul Avenue · Waukesha, WI 53188-4999
Phone: (262) 547-3311 · Fax: (262) 549-2795

©2008 Dresser Inc. Waukesha, VGF, WKI, and Enginotor are trademarks/registered trademarks of Dresser Waukesha, Dresser, Inc.



Waukesha

www.dresser.com