

STANDARD EQUIPMENT

- AIR CLEANERS** – Two, 3" dry type filter with hinged rain shield and service indicator.
- BARRING DEVICE** – Manual.
- BEARINGS** – Heavy duty, replaceable, precision type.
- BREATHER** – Self regulating, closed system.
- CONNECTING RODS** – Forged steel, rifle drilled.
- CONTROL SYSTEM** – Waukesha Engine System Manager (ESM®) integrates spark timing control, speed governing, start-stop control, diagnostic tools, fault logging and engine safeties. Engine Control Unit (ECU) is central brain of the control system and main customer interface. Interface with ESM is through 25 foot (7.6 m) harness to local panel, through MODBUS RTU slave connection RS-485 multidrop hardware, and through the Electronic Service Program (ESP). Customer connections are only required to the local panel, fuel valve, and for 24V DC power supply. ESM meets Canadian Standards Association Class I, Division 2, Group D, hazardous location requirements. Includes 25ft customer interface harnesses.
- COOLING SYSTEM** – Choice of mounted radiator with pusher fan, core guard and duct adapter, heat exchanger with expansion tank, or connection for remote radiator cooling. (One shutdown level switch for each circuit included on radiator and heat exchange units).
- CRANKCASE** – Integral crankcase and cylinder frame.
- CRANKSHAFT** – Counterweighted, forged steel, hardened journals, dynamically balanced, with sealed viscous vibration damper.
- CYLINDER HEADS** – Interchangeable valve-in-head type. Two hard faced intake and two hard faced inconel exhaust valves per cylinder. Hard faced intake and exhaust valve seat inserts. Includes prechamber.
- CYLINDERS** – 7100GL Series, 9.375" (238 mm) bore x 8.5" (216 mm) stroke. Removable wet cylinder liners. Number of cylinders - Twelve.
- ELECTRONIC SERVICE PROGRAM (ESP)** – Microsoft® Windows-based program provided on CD-ROM for programming and interface to ESM. Includes E-Help for troubleshooting any ESM faults. Serial harness is provided for connection of a customer supplied laptop to the ECU RS-232 port.
- ENGINATOR BASE** – Engine, generator and radiator or heat exchanger are mounted and aligned on a welded steel, wide flange base, suitable for solid or isolator mounting with base lifting eyes.
- ENGINE MONITORING DEVICES** – Factory mounted and wired sensors for lube oil pressure and temperature, intake manifold temperature and pressure, and jacket water temperature, all accessible through ESM. ESM continually monitors combustion performance through accelerometers to provide detonation protection. Dual magnetic pick-ups are used for accurate engine speed monitoring. ESM provides advanced diagnostics of engine and all ESM sensors and logs any faults into non-volatile flash memory. Exhaust thermocouples 14 points with 25ft customer interface harness.
- EXHAUST SYSTEM** - Water cooled exhaust manifold with single vertical exhaust at rear. Flexible stainless steel exhaust connection 8" (203 mm) long with 8" (203 mm) outlet flange.
- FUEL SYSTEM** – Two natural gas 4" updraft carburetors, two Mooney Flowgrid 250 gas regulators, one 3" flanged flexible connection (shipped loose), and one 2" NPT Magnetrol gas solenoid valve (shipped loose). Fuel pressure – 43 PSIG minimum and 50 PSIG maximum. Prechamber fuel system control logic.
- GENERATOR** - Open, dripproof, direct connected, fan cooled, 2/3 pitch A.C. revolving field type, single bearing generator with brushless exciter, short circuit sustain (PMG type maintains 270% of rated generator current for up to 10 seconds on 105 ° C temperature rise generators; maintains 250% of current on 130 ° C rise generators) and damper windings. TIF and Deviation Factor within NEMA MG-1.32. Voltage 480/277, 3 phase, 4 wire, Wye, 60 Hz and 400/220, 3 phase, 4 wire, Wye 50 Hz. Other voltages are available, consult factory. Insulation material NEMA Class F. Temperature rise within NEMA (105° C) for continuous power duty, within NEMA (130° C) for standby duty. All generators are rated 0.8 Power Factor, are mounted on the engine flywheel housing and have multiple steel disc flexible coupling drive. Includes space heater, 115/230 V, 1 phase.
- GOVERNOR** – Electric throttle actuator controlled by ESM with throttle position feedback. Governor tuning is performed using ESP. ESM includes option of a load-coming feature to improve engine response to step loads.
- IGNITION SYSTEM** – Ignition Power Module Diagnostics (IPM-D) controlled by ESM, with spark timing optimized for any speed-load condition. Dual voltage energy levels automatically controlled by ESM to maximize spark plug life.
- INTERCOOLER** – Air to water.
- JUNCTION BOXES** – Separate AC and DC junction boxes for engine wiring and external connections.
- LUBRICATION** – Full pressure, gear type pump. Engine mounted full flow lube oil micro-fiberglass filters. Microspin® bypass filter, engine mounted. 50 or 60 Hz, 230 volt AC, single phase electric motor driven intermittent prelube pump with motor starter (other voltages can be specified). ESM® controlled start/stop prelube pump.
- OIL COOLER** – Shell and tube type (mounted).
- OIL PAN** – Deep sump type. 190 gallon (719 L) capacity including filter and cooler.
- PAINT** – Oilfield Orange.
- PISTONS** – Aluminum with floating pin. Oil cooled.
- STARTING EQUIPMENT** – Two 24VDC electric starting motors.
- TURBOCHARGERS** – Dry type, wastegate controlled.
- VOLTAGE REGULATOR** (shipped loose) – SCR static automatic type providing 1% regulation from no load to full load, three phase sensing and automatic subsynchronous speed protection. Includes voltage adjustment rheostat (shipped loose).
- WATER CIRCULATING SYSTEM, AUXILIARY CIRCUIT** – Belt driven water circulating high capacity pump for intercooler and lube oil cooler. See S6543-38 performance curve for use with standard 10" diameter crankshaft pulley. Includes thermostatic valve.
- WATER CIRCULATING SYSTEM, ENGINE JACKET** – Belt driven water pump, 175 – 180° F (79 – 82° C) thermostatic temperature regulation with full flow bypass. Single ANSI flange connections for inlet and outlet on water connect units.

VHP® Series Gas Enginator® Generating System Featuring ESM® Technology

845 - 1210 kW

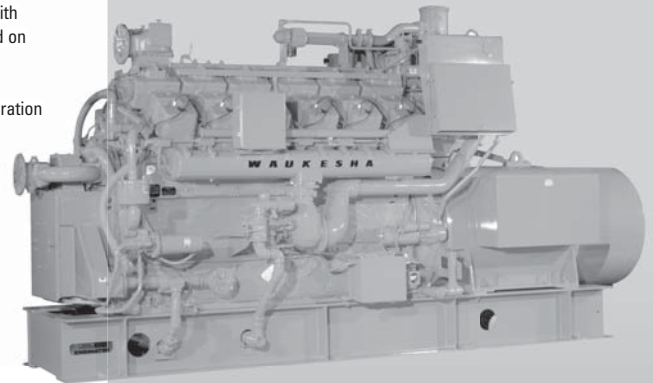

Enginator shown with options.

Model VHP7100GL

Turbocharged and Intercooled, Lean Combustion Gas Fueled Enginator

SPECIFICATIONS

Waukesha Engine	Jacket Water Capacity
7042GL,	100 gal.
Four Cycle,	(379 L)
Overhead Valve	
Cylinders	Starting System
V 12	24V Electric
Piston	Fuel LHV
Displacement	900 Btu/ft ³
7040 cu. in.	(33.5 J/cm ³)
(115 L)	Lube Oil Capacity
Bore & Stroke	190 gal.
9.375" x 8.5"	(719 L)
(238 x 216 mm)	
Compression Ratio	
10.5:1	



PERFORMANCE DATA: VHP7100GL GAS ENGINATOR GENERATING SYSTEM

HEAT EXCHANGER COOLING Intercooler Water: 85°F (29°C)	CONTINUOUS POWER*		STANDBY POWER	
	1200 rpm 60 Hz	1000 rpm 50 Hz	1200 rpm 60 Hz	1000 rpm 50 Hz
kW RATING	1100	920	1210	1015
Fuel Consumption x 1000 Btu/h (kW)	11390 (3338)	9339 (2737)	12290 (3602)	10196 (2988)
Jacket Water x 1000 Btu/h (kW)	2678 (785)	2335 (684)	2840 (832)	2498 (732)
Lube Oil x 1000 Btu/h (kW)	450 (132)	413 (121)	460 (135)	433 (127)
Intercooler x 1000 Btu/h (kW)	760 (223)	645 (189)	840 (246)	747 (219)
Heat Radiated x 1000 Btu/h (kW)	443 (130)	455 (133)	421 (124)	429 (126)
Exhaust Energy** x 1000 Btu/h (kW)	3306 (969)	2352 (689)	3600 (1055)	2626 (770)
Exhaust Flow lb/h (kg/h)	16596 (7528)	13420 (6087)	17910 (8124)	14851 (6736)
Exhaust Temperature °F (°C)	791 (422)	712 (378)	800 (427)	720 (382)
Induction Air Flow scfm (nm ³ /hr)	3730 (5990)	3061 (4920)	4030 (6480)	3337 (5360)

WATER CONNECTION COOLING Intercooler Water: 130°F (54°C)	CONTINUOUS POWER*		STANDBY POWER	
	1200 rpm 60 Hz	1000 rpm 50 Hz	1200 rpm 60 Hz	1000 rpm 50 Hz
kW RATING	1050	875	1155	965
Fuel Consumption x 1000 Btu/h (kW)	10750 (3151)	8600 (2521)	11650 (3415)	9335 (2736)
Jacket Water x 1000 Btu/h (kW)	2815 (825)	2235 (655)	3010 (882)	2400 (703)
Lube Oil x 1000 Btu/h (kW)	430 (126)	340 (100)	449 (132)	358 (105)
Intercooler x 1000 Btu/h (kW)	543 (159)	368 (108)	616 (180)	452 (132)
Heat Radiated x 1000 Btu/h (kW)	328 (96)	305 (89)	332 (97)	308 (90)
Exhaust Energy** x 1000 Btu/h (kW)	3085 (904)	2380 (697)	3370 (988)	2580 (756)
Exhaust Flow lb/h (kg/h)	15890 (7209)	12715 (5768)	17200 (7830)	13825 (6273)
Exhaust Temperature °F (°C)	709 (376)	679 (360)	719 (381)	683 (362)
Induction Air Flow scfm (nm ³ /hr)	3500 (5620)	2800 (4500)	3800 (6110)	3045 (4890)

RADIATOR COOLING - MOUNTED Intercooler Water: 130°F (54°C)	CONTINUOUS POWER*		STANDBY POWER	
	1200 rpm 60 Hz	1000 rpm 50 Hz	1200 rpm 60 Hz	1000 rpm 50 Hz
kW RATING	1025	845	1130	930
Fuel Consumption x 1000 Btu/h (kW)	10750 (3151)	8600 (2521)	11650 (3415)	9335 (2736)
Jacket Water x 1000 Btu/h (kW)	2815 (825)	2235 (655)	3010 (882)	2400 (703)
Lube Oil x 1000 Btu/h (kW)	430 (126)	340 (100)	449 (132)	358 (105)
Intercooler x 1000 Btu/h (kW)	543 (159)	368 (108)	616 (180)	452 (132)
Heat Radiated x 1000 Btu/h (kW)	328 (96)	305 (89)	332 (97)	308 (90)
Exhaust Energy** x 1000 Btu/h (kW)	3085 (904)	2380 (697)	3370 (988)	2580 (756)
Exhaust Flow lb/h (kg/h)	15890 (7209)	12715 (5768)	17200 (7830)	13825 (6273)
Exhaust Temperature °F (°C)	709 (376)	679 (360)	719 (381)	683 (362)
Induction Air Flow scfm (nm ³ /hr)	3500 (5620)	2800 (4500)	3800 (6110)	3045 (4890)
Radiator Air Flow scfm (m ³ /min)	100000 (2680)	85000 (2280)	97000 (2600)	86000 (2300)

Typical heat balance data is shown. Consult factory for guaranteed data.

***Continuous Power Rating:** The highest electrical power output of the Enginator available for an unlimited number of hours per year, less maintenance. It is permissible to operate the Enginator with up to 10% overload for two hours in each 24 hour period.

Standby Power Rating: This rating applies to those systems used as a secondary source of electrical power. This rating is the electrical power output of the Enginator (no overload) 24 hours a day, for the duration of the primary power source outage.

Rating Standard: The Waukesha Enginator power rating descriptions are in accordance to ISO 8528, DIN6271 and BS5514. It is also valid for ISO 3046/1-1986 with an engine mechanical efficiency of 90% and Tcr (clause 10.0) is limited to ± 10° F (5° C).

**Heat rejection based on cooling exhaust gas to 85° F (29° C).

All natural gas engine ratings are based on a fuel of 900 Btu/ft³ (35.3 MJ/nm³) SLHV, with a 91 WKI®. For conditions or fuels other than standard, consult Dresser Waukesha Application Engineering Department.

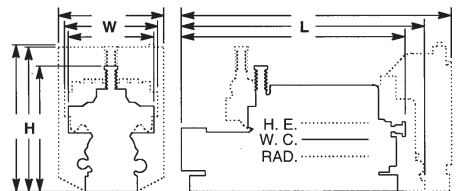

Equipment	L in (mm)	W in (mm)	H in (mm)	Avg. Wt. lb (kg)
Heat Exchanger	235 (5970)	85 (2160)	103 (2620)	40000 (18140)
Water Connection	205 (5208)	85 (2160)	103 (2620)	38000 (17230)
Radiator	260 (6600)	124 (3150)	160 (4060)	46000 (20860)

Consult your local Waukesha Distributor for system application assistance. The manufacturer reserves the right to change or modify without notice, the design or equipment specifications as herein set forth without incurring any obligation either with respect to equipment previously sold or in the process of construction except where otherwise specifically guaranteed by the manufacturer.

Bulletin 8016 1008

Dresser Waukesha
1101 West St. Paul Avenue · Waukesha, WI 53188-4999
Phone: (262) 547-3311 · Fax: (262) 549-2795

©2008 Dresser Inc. Waukesha, VHP, WKI, and Enginator are trademarks/registered trademarks of Dresser Waukesha, Dresser, Inc.



Waukesha

www.dresser.com