



# Waukesha

# VHP5904GSI/GSID

## STANDARD EQUIPMENT

- AIR CLEANERS** – Two, 3" dry type filter with hinged rain shield and service indicator.
- AIR FUEL RATIO CONTROL (AFR)** – Integrated ESM–AFR catalyst rich-burn control, main fuel gas regulators actuators, exhaust O<sub>2</sub> sensor(s), and post turbocharger exhaust thermocouple. Factory mounted and tested. AFR maintains emissions through load and speed changes. The ESM–AFR meets Canadian Standards Association Class 1, Division 2, Group D hazardous location requirements. Note: For dual fuel applications, ESM–AFR system will control the primary fuel source only.
- BARRING DEVICE** – Manual.
- BEARINGS** – Heavy duty, replaceable, precision type.
- BREATHER** – Self regulating, closed system.
- CONNECTING RODS** – Forged steel, rifle drilled.
- COOLING SYSTEM** – Choice of mounted radiator with pusher fan, core guard and duct adapter, heat exchanger with expansion tanks, or connection for remote radiator cooling. (One shutdown level switch for each circuit included on radiator and heat exchanger units).
- CONTROL SYSTEM** – Waukesha Engine System Manager (ESM) integrates spark timing control, speed governing, detonation detection, start-stop control, diagnostic tools, fault logging and engine safeties. Engine Control Unit (ECU) is central brain of the control system and main customer interface. Connection to the ESM is via a 25 foot (7.6 m) harness to a local panel, through MODBUS RTU slave RS-485 connection, and through the Electronic Service Program (ESP). Customer connections are only required to the local panel, fuel valve, and for 24V DC power supply. Compatible with Woodward load sharing module. ESM meets Canadian Standards Association Class 1, Division 2, Group D, hazardous location requirements.
- CRANKCASE** – Integral crankcase and cylinder frame.
- CRANKSHAFT** – Counterweighted, forged steel, dynamically balanced, with sealed viscous vibration damper.
- CYLINDER HEADS** – Interchangeable valve-in-head type. Four valves per cylinder with water cooled exhaust valve seat. Roller valve lifters and hydraulic push rods. Flange mounted ignition coils.
- CYLINDERS** - VHP7104GSI/GSID 9.375" (238 mm) bore x 8.5" (216 mm) stroke; VHP5904GSI/GSID 8.5" (216 mm) bore x 8.5" (216 mm) stroke. Removable wet cylinder liners, chrome plated on outer diameter. Number of cylinders - Twelve.
- ENGINE BASE** – Engine, generator and radiator or heat exchanger are mounted and aligned on a welded steel, wide flange base, suitable for solid, or spring isolator mounting on a proper foundation. Base is equipped with lifting eyes.
- ELECTRONIC SERVICE PROGRAM (ESP)** – Microsoft® Windows-based program provided on CD-ROM for programming and interface to ESM. Includes E-Help for troubleshooting any ESM faults. Serial harness is provided for connection of a customer supplied laptop to the ECU RS-232 port.
- ENGINE MONITORING DEVICES** – Factory mounted and wired sensors for lube oil pressure and temperature, intake manifold temperature and pressure, and jacket water temperature, all accessible through ESM®. ESM continually monitors combustion performance through accelerometers to provide detonation protection. Dual magnetic pick-ups are used for accurate engine speed monitoring. ESM provides advanced diagnostics of engine and all ESM sensors and logs any faults into non-volatile flash memory.
- EXHAUST SYSTEM** - Water cooled exhaust manifold with single vertical exhaust at rear. Flexible stainless steel exhaust connection 8" (203 mm) long with 8" outlet flange.
- FUEL SYSTEM (GSI)** – Two natural gas, 4" (102 mm) updraft carburetors and two mounted Mooney Flowgrid 250, 2" (51 mm) gas regulator, one 3" flanged flexible connection (shipped loose), and one 2" NPT Magnatrol gas solenoid valve (shipped loose). Fuel pressure – 30 PSIG minimum and 50 PSIG maximum.
- FUEL SYSTEM (GSID)** – Two natural gas 4" updraft carburetors, two Fisher 133L gas regulators (shipped loose), two flexible connections (shipped loose), and one 3" NPT Magnatrol gas solenoid valve (shipped loose). Fuel pressure – 3.25 PSIG minimum and 50 PSIG maximum.
- GENERATOR** - Open, dripproof, direct connected, fan cooled, 2/3 pitch, A.C. revolving field type, single bearing generator with brushless exciter, short circuit sustain (PMG type maintains 270% of rated generator current for up to 10 seconds on 105° C temperature rise generators; maintains 250% of current on 130° C rise generators) and damper windings. TIF and Deviation Factor within NEMA MG-1.32. Voltage 480/277, 3 phase, 4 wire, Wye 60 Hz and 400/230, 3 phase, 4 wire, Wye 50 Hz. Other voltages are available, consult factory. Insulation material NEMA Class F. Temperature rise within NEMA (105° C) for continuous power duty, within NEMA (130° C) for standby duty. All generators are rated at 0.8 Power Factor, are mounted on the engine flywheel housing and have multiple steel disc flexible coupling drive. Includes space heater, 115/230 V, 1 phase.
- GOVERNOR** – Electric throttle actuator controlled by ESM with throttle position feedback. Governor tuning is performed using ESP. ESM includes option of a load-coming feature to improve engine response to step loads.
- IGNITION SYSTEM** – Ignition Power Module Diagnostics (IPM-D) controlled by ESM, with spark timing optimized for any speed-load condition. Dual voltage energy levels automatically controlled by ESM to maximize spark plug life. Shielded ignition components that meet Canadian Standard Association Class 1, Division 2, Group D hazardous location requirements.
- INTERCOOLER** – Air to water.
- JUNCTION BOXES** – Separate AC and DC junction boxes for engine wiring and external connections.
- LUBRICATION** – Full pressure, gear type pump. Engine mounted full flow lube oil micro-fiberglass filters. Microspin® bypass filter, engine mounted. 50 or 60 Hz, 230 volt AC, single phase electric motor driven intermittent prelube pump with motor starter (other voltages can be specified).
- OIL COOLER** – Shell and tube type (mounted).
- OIL PAN** – Deep sump type. 190 gallon (719 L) capacity including filter and cooler.
- PAINT** – Oilfield Orange.
- PISTONS** – Aluminum with floating pin. Oil cooled.
- STARTING EQUIPMENT** – Two 24V DC electric starting motor.
- TURBOCHARGERS** – Water cooled bearing housing. VHP5904GSID differential wastegate; 7104GSID adjustable wastegate.
- VOLTAGE REGULATOR** (shipped loose) – SCR static automatic type providing 1% regulation from no load to full load, three phase sensing and automatic subsynchronous speed protection. Includes voltage adjustment rheostat (shipped loose).
- WATER CIRCULATING SYSTEM, AUXILIARY CIRCUIT** – Belt driven water circulating high capacity pump for intercooler and lube oil cooler. See S6543-36 performance curve for use with standard 10" diameter crankshaft pulley.
- WATER CIRCULATING SYSTEM, ENGINE JACKET** – Belt driven water pump, 175 – 180° F (79 – 82° C) thermostatic temperature regulation full flow bypass. Single ANSI flange connections for inlet and outlet on water connect units.

## VHP® Series Four® Gas Enginator® Generating System Featuring ESM® Technology

860 - 1080 kW

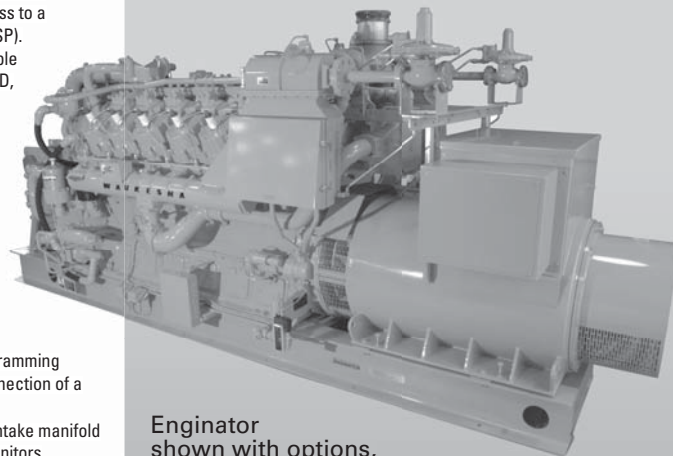

Enginator shown with options, less Extender Series feature.

## Model VHP5904GSI/GSID

Turbocharged and Intercooled Gas Fueled Enginator

## SPECIFICATIONS

<b>Waukesha Engine</b>	<b>Jacket Water Capacity</b>
L5794GSI	107 gal.
Four Cycle	(405 L)
<b>Cylinders</b>	<b>Starting System</b>
V 12	24V Electric
<b>Piston</b>	<b>Fuel LHV</b>
<b>Displacement</b>	900 Btu/ft <sup>3</sup>
5788 cu. in.	(33.5 J/cm <sup>3</sup> )
(95 L)	<b>Lube Oil Capacity</b>
<b>Bore &amp; Stroke</b>	190 gal.
8.5" x 8.5"	(719 L)
(216 x 216 mm)	
<b>Compression Ratio</b>	
8.2:1	



PERFORMANCE DATA: VHP5904GSI/GSID GAS ENGINATOR® GENERATING SYSTEM

HEAT EXCHANGER COOLING Heat Exchanger Water Supply: 93°F (34°C) I.C. Water: 130°F (54°C)	Continuous Power*		Standby Power	
	1200 rpm 60 Hz	1000 rpm 50 Hz	1200 rpm 60 Hz	1000 rpm 50 Hz
kW RATING	980 kW	900 kW	1080 kW	900 kW
BSFC	7660 (10838)	7280 (10301)	7550 (10683)	7302 (10332)
Fuel Consumption x 1000 Btu/h (kW)	10615 (3215)	9390 (2752)	11545 (3383)	9390 (2752)
Jacket Water x 1000 Btu/h (kW)	3080 (903)	2710 (794)	3275 (960)	2710 (794)
Lube Oil x 1000 Btu/h (kW)	474 (139)	390 (114)	489 (143)	390 (114)
Intercooler x 1000 Btu/h (kW)	130 (38)	95 (28)	152 (45)	95 (28)
Heat Radiated x 1000 Btu/h (kW)	652 (191)	604 (177)	684 (200)	604 (177)
Exhaust Energy** x 1000 Btu/h (kW)	2935 (860)	2520 (738)	3260 (955)	2520 (738)
Exhaust Flow lb/h (kg/h)	9050 (4113)	8005 (3632)	9840 (4465)	8005 (3632)
Exhaust Temperature °F (°C)	1138 (614)	1102 (594)	1159 (626)	1102 (594)
Induction Air Flow scfm (nm <sup>3</sup> /hr)	1940 (3120)	1720 (2760)	2110 (3390)	1720 (2760)

WATER CONNECTION COOLING I.C. Water: 130°F (54°C)	1200 rpm 60 Hz	1000 rpm 50 Hz	1200 rpm 60 Hz	1000 rpm 50 Hz
	980 kW	900 kW	1080 kW	900 kW
BSFC	7660 (10838)	7280 (10301)	7550 (10683)	7302 (10332)
Fuel Consumption x 1000 Btu/h (kW)	10615 (3215)	9390 (2752)	11545 (3383)	9390 (2752)
Jacket Water x 1000 Btu/h (kW)	3080 (903)	2710 (794)	3275 (960)	2710 (794)
Lube Oil x 1000 Btu/h (kW)	474 (139)	390 (114)	489 (143)	390 (114)
Intercooler x 1000 Btu/h (kW)	130 (38)	95 (28)	152 (45)	95 (28)
Heat Radiated x 1000 Btu/h (kW)	652 (191)	604 (177)	684 (200)	604 (177)
Exhaust Energy** x 1000 Btu/h (kW)	2935 (860)	2520 (738)	3260 (955)	2520 (738)
Exhaust Flow lb/h (kg/h)	9050 (4113)	8005 (3632)	9840 (4465)	8005 (3632)
Exhaust Temperature °F (°C)	1138 (614)	1102 (594)	1159 (626)	1102 (594)
Induction Air Flow scfm (nm <sup>3</sup> /hr)	1940 (3120)	1720 (2760)	2110 (3390)	1720 (2760)

RADIATOR COOLING - MOUNTED I.C. Water: 130°F (54°C)	1200 rpm 60 Hz	1000 rpm 50 Hz	1200 rpm 60 Hz	1000 rpm 50 Hz
	940 kW	860 kW	1030 kW	860 kW
BSFC	7660 (10838)	7280 (10301)	7550 (10683)	7302 (10332)
Fuel Consumption x 1000 Btu/h (kW)	10615 (3215)	9390 (2752)	11545 (3383)	9390 (2752)
Jacket Water x 1000 Btu/h (kW)	3080 (903)	2710 (794)	3275 (960)	2710 (794)
Lube Oil x 1000 Btu/h (kW)	474 (139)	390 (114)	489 (143)	390 (114)
Intercooler x 1000 Btu/h (kW)	130 (38)	95 (28)	152 (45)	95 (28)
Heat Radiated x 1000 Btu/h (kW)	652 (191)	604 (177)	684 (200)	604 (177)
Exhaust Energy** x 1000 Btu/h (kW)	2935 (860)	2520 (738)	3260 (955)	2520 (738)
Exhaust Flow lb/h (kg/h)	9050 (4113)	8005 (3632)	9840 (4465)	8005 (3632)
Exhaust Temperature °F (°C)	1138 (614)	1102 (594)	1159 (626)	1102 (594)
Induction Air Flow scfm (nm <sup>3</sup> /hr)	1940 (3120)	1720 (2760)	2110 (3390)	1720 (2760)
Radiator Air Flow scfm (m <sup>3</sup> /min)	100000 (2680)	85000 (2280)	100000 (2680)	86000 (2300)

Typical heat balance data is shown. Consult factory for guaranteed data.

\*Continuous Power Rating: The highest electrical power output of the Enginator available for an unlimited number of hours per year, less maintenance. It is permissible to operate the 60 Hz Enginator units with up to 10% overload for two hours in each 24 hour period. NO overload is allowed for the 50 Hz units.

Rating Standard: The Waukesha Enginator power rating descriptions are in accordance to ISO 8528, DIN6271 and BS5514. It is also valid for ISO 3046/1-1995 with an engine mechanical efficiency of 90% and auxiliary water temperature Tcr (clause 10.0) is limited to ±10° F (5° C).

\*\*Heat rejection based on cooling exhaust gas to 85° F (29° C).

All natural gas engine ratings are based on a fuel of 900 Btu/ft<sup>3</sup> (35.3 MJ/nm<sup>3</sup>) SLHV, with a 91 WK1®. For conditions or fuels other than standard, consult Dresser Waukesha Application Engineering Department.

Equipment	L in (mm)	W in (mm)	H in (mm)	Avg. Wt. lb (kg)
Heat Exchanger	235 (5970)	85 (2160)	103 (2620)	40000 (18140)
Water Connection	205 (5208)	85 (2160)	103 (2620)	38000 (17230)
Radiator	260 (6600)	124 (3150)	160 (4060)	46000 (20860)

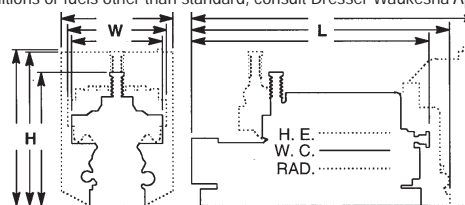

Consult your local Waukesha Distributor for system application assistance. The manufacturer reserves the right to change or modify without notice, the design or equipment specifications as herein set forth without incurring any obligation either with respect to equipment previously sold or in the process of construction except where otherwise specifically guaranteed by the manufacturer.

Bulletin 7018 1008

Dresser Waukesha  
1101 West St. Paul Avenue · Waukesha, WI 53188-4999  
Phone: (262) 547-3311 · Fax: (262) 549-2795

©2008 Dresser Inc. Waukesha, VHP, Microspim, ESM, and Enginator are trademarks/registered trademarks of Dresser Waukesha, Dresser, Inc.



www.dresser.com