



## STANDARD EQUIPMENT

- AIR CLEANER** – Two stage, dry panel type with rain shield and service indicator. Engine mounted.
- BARRING DEVICE** – Manual.
- BASE** – Engine, generator and radiator or heat exchanger are mounted and aligned on a welded steel wide flange base, suitable for solid, or spring isolator mounting on a proper foundation. Base is equipped with lifting eyes and provision for jacking.
- BREATHER** – Closed system.
- CONNECTING RODS** – Drop forged alloy steel, angle split, serrated joint, oil jet piston pin lubrication.
- COOLING SYSTEM** – Choice of mounted radiator with pusher fan, core guard and duct adaptor, heat exchanger with shipped loose expansion tank or flanged connections for remote radiator cooling.
- CRANKCASE** – Alloy cast iron, fully ribbed, integral with cylinder frame.
- CRANKSHAFT** – Drop forged alloy steel with thru hardened journals, dynamically balanced and fully counterweighted. Viscous vibration dampener.
- CYLINDER HEADS** – Individual, interchangeable valve-in-head type with deep section alloy casting. Two hard-faced intake and two hard-faced exhaust valves per cylinder. Replaceable intake and exhaust valve seats. Mechanical valve lifters with pivoted roller followers.
- CYLINDERS** – Removable wet type liners of centrifugally cast alloy iron.
- ENGINE PROTECTION SHUTDOWN CONTACTS** – High water temperature, low oil pressure, and overspeed.
- EXHAUST** – Water-cooled, cast iron exhaust manifolds. Single vertical flexible stainless steel exhaust connection with ANSI 10" 125# outlet flange.
- FUEL SYSTEM (GL)** – Two natural gas carburetors, one Fisher Y692 gas regulator, one 2" NPT flexible connection (shipped loose) and one 2" NPT Magnatrol gas solenoid valve (shipped loose). Fuel pressure - 25 PSIG minimum and 50 PSIG maximum.
- FUEL SYSTEM (GLD)** – Two natural gas carburetors, one DUNGS 5080 gas regulator (shipped loose), one 3" NPT flexible connection (shipped loose), and one 2" NPT Magnatrol gas solenoid valve (shipped loose). Fuel pressure - 5 PSIG minimum and 8 PSIG maximum.
- GENERATOR** – Open, drip-proof, direct connected, synchronous, fan cooled, AC revolving field type, 2/3 pitch, single bearing generator with PMG brushless exciter for 300% short circuit sustain for 10 seconds (250% for 50 Hz) and motor starting. TIF and Deviation Factor within NEMA MG-1.32. Voltage: 480/277, 3 phase, 6 or 12 wire Wye, 60 Hz, and 400/230, 3 phase, 6 or 12 wire Wye, 50 Hz. Temperature rise within NEMA 105° C for continuous duty, within NEMA 130° C for standby duty. Voltage regulation is ±0.5%. All generators are rated at 0.8 power factor, are mounted on the engine flywheel housing, and have multiple steel disc flexible coupling drive.
- GOVERNOR** – Woodward model EG3P electric actuator (mounted) and magnetic pick-up (mounted). Requires a separate electric governor control, Woodward Model 2301D(not included). See Code 6020D.
- IGNITION** – Waukesha Custom Engine Control electronic ignition system with coils, cables, hall effect pickup and spark plugs. Non-shielded. 24V DC power required. Includes emergency stop/service engine protection switch for local override of remote controls.
- INTERCOOLER** – Air to water.
- INSTRUMENT PANEL** – Engine mounted, includes water temperature, oil temperature, oil pressure, intake manifold temperature and intake manifold pressure gauges.
- JUNCTION BOXES** – Separate AC & DC junction boxes for engine wiring and external connections.
- LUBRICATION SYSTEM** – Gear type pump, replaceable spin on oil filters and industrial base type oil pan. Engine mounted shell and tube oil cooler, thermostatic valve for oil temperature control, and prelube pump. Engine mounted 230 VAC, single phase 50/60 Hz, or 208 VAC, single phase 60Hz, electric driven prelube pump with motor starter. Continuous prelube not available.
- PAINT** – Oilfield Orange.
- PISTONS** – Aluminum alloy, three ring, with patented high turbulence combustion bowl. Oil jet cooled with full floating piston pin. 11:1 compression ratio.
- STARTING SYSTEM** – 24V DC starting motor. Crank termination switch, (shipped loose).
- TURBOCHARGERS** – Dry-type with wastegate.
- VOLTAGE REGULATOR** – Automatic type (shipped loose).
- WATER CIRCULATING SYSTEM, AUXILIARY CIRCUIT** – Gear driven pump for intercooler and oil cooler. Inlet temperature of 130° F (54° C) for all models.
- WATER CIRCULATING SYSTEM, JACKET WATER CIRCUIT** – 180° – 190° F (82° – 88° C) thermostatic temperature regulation. Gear-driven pump.
- WAUKESHA CUSTOM ENGINE CONTROL DETONATION SENSING MODULE (DSM)** – Includes individual cylinder sensors, Detonation Sensing Module, and filter. Device is compatible with Waukesha CEC Ignition Module only. Detonation Sensing Module and DSM Filter are mounted and wired. 24V DC power is required. The DSM meets Canadian Standards Association Class I, Division 2, Group D, hazardous location requirements.

## VGF® Series Gas Enginator® Generating System

440 - 645 kW

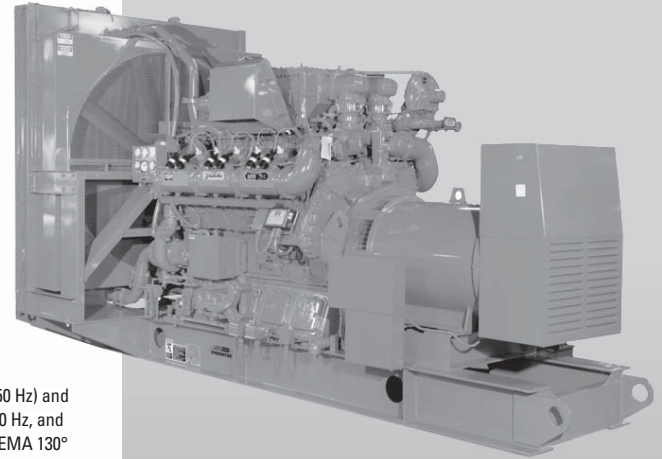

## Model VGF36GL/GLD

Turbocharged and Intercooled, Lean Combustion Gas Fueled Enginator

## SPECIFICATIONS

<b>Waukesha Engine</b> P36GL/GLD	<b>Jacket Water Capacity</b>
<b>Cylinders</b> V 12	44 gal. (166 L)
<b>Piston Displacement</b> 2193 cu. in. (36 L)	<b>Starting System</b> 24V DC Electric
<b>Bore &amp; Stroke</b> 5.98" x 6.5" (152 x 165 mm)	<b>Fuel SLHV</b> 900 Btu/ft <sup>3</sup> (35.3 MJ/m <sup>3</sup> )
<b>Compression Ratio</b> 11:1	<b>Lube Oil Capacity</b> 86 gal. (326 L)



## PERFORMANCE DATA: VGF36GL/GLD GAS ENGINEATOR GENERATING SYSTEM

HEAT EXCHANGER COOLING Intercooler Water: 130°F (54°C)	CONTINUOUS POWER*		STANDBY POWER	
	1800 rpm	1500 rpm	1800 rpm	1500 rpm
<b>kW RATING</b>	<b>620***</b>	<b>515***</b>	<b>645</b>	<b>535</b>
Fuel Consumption x 1000 Btu/h (kW)	6165 (1806)	4995 (1463)	6430 (1885)	5215 (1528)
Jacket Water x 1000 Btu/h (kW)	1565 (458)	1323 (388)	1615 (473)	1367 (401)
Intercooler x 1000 Btu/h (kW)	392 (115)	269 (79)	425 (125)	297 (87)
Lube Oil x 1000 Btu/h (kW)	194 (57)	139 (41)	197 (58)	141 (41)
Heat Radiated x 1000 Btu/h (kW)	115 (34)	107 (31)	116 (34)	107 (31)
Exhaust Heat** x 1000 Btu/h (kW)	1710 (501)	1339 (392)	1790 (525)	1395 (409)
Exhaust Flow lb/h (kg/h)	7950 (3607)	6475 (2936)	8320 (3774)	6785 (3078)
Exhaust Temperature °F (°C)	841 (449)	804 (429)	843 (451)	800 (427)
Induction Air Flow scfm (m³/min)	1740 (45)	1415 (36)	1820 (46)	1485 (38)

WATER CONNECTION COOLING Intercooler Water: 130°F (54°C)	CONTINUOUS POWER*		STANDBY POWER	
	1800 rpm	1500 rpm	1800 rpm	1500 rpm
<b>kW RATING</b>	<b>620***</b>	<b>515***</b>	<b>645</b>	<b>535</b>
Fuel Consumption x 1000 Btu/h (kW)	6165 (1806)	4995 (1463)	6430 (1885)	5215 (1528)
Jacket Water x 1000 Btu/h (kW)	1565 (458)	1323 (388)	1615 (473)	1367 (401)
Intercooler x 1000 Btu/h (kW)	392 (115)	269 (79)	425 (125)	297 (87)
Lube Oil x 1000 Btu/h (kW)	194 (57)	139 (41)	197 (58)	141 (41)
Heat Radiated x 1000 Btu/h (kW)	115 (34)	107 (31)	116 (34)	107 (31)
Exhaust Heat** x 1000 Btu/h (kW)	1710 (501)	1339 (392)	1790 (525)	1395 (409)
Exhaust Flow lb/h (kg/h)	7950 (3607)	6475 (2936)	8320 (3774)	6785 (3078)
Exhaust Temperature °F (°C)	841 (449)	804 (429)	843 (451)	800 (427)
Induction Air Flow scfm (m³/min)	1740 (45)	1415 (36)	1820 (46)	1485 (38)

RADIATOR COOLING - MOUNTED Intercooler Water: 130°F (54°C)	CONTINUOUS POWER*		STANDBY POWER	
	1800 rpm	1500 rpm	1800 rpm	1500 rpm
<b>kW RATING</b>	<b>590***</b>	<b>500***</b>	<b>625</b>	<b>525</b>
Fuel Consumption x 1000 Btu/h (kW)	6165 (1806)	4995 (1463)	6430 (1885)	5215 (1528)
Jacket Water x 1000 Btu/h (kW)	1565 (458)	1323 (388)	1615 (473)	1367 (401)
Intercooler x 1000 Btu/h (kW)	392 (115)	269 (79)	425 (125)	297 (87)
Lube Oil x 1000 Btu/h (kW)	194 (57)	139 (41)	197 (58)	141 (41)
Heat Radiated x 1000 Btu/h (kW)	115 (34)	107 (31)	116 (34)	107 (31)
Exhaust Heat** x 1000 Btu/h (kW)	1710 (501)	1339 (392)	1790 (525)	1395 (409)
Exhaust Flow lb/h (kg/h)	7950 (3607)	6475 (2936)	8320 (3774)	6785 (3078)
Exhaust Temperature °F (°C)	841 (449)	804 (429)	843 (451)	800 (427)
Induction Air Flow scfm (m³/min)	1740 (45)	1415 (36)	1820 (46)	1485 (38)
Radiator Air Flow scfm (m³/min)	75000 (2124)	63000 (1784)	75000 (2124)	63000 (1784)

Typical heat rejection data is shown. Consult factory for guaranteed data.

\***Continuous Power Rating:** The highest electrical power output of the Enginotor available for an unlimited number of hours per year, less maintenance. It is permissible to operate the Enginotor with up to 10% overload for two hours in each 24 hour period.

**Standby Power Rating:** This rating applies to those systems used as a secondary source of electrical power. This rating is the electrical power output of the Enginotor (no overload) 24 hours a day, for the duration of the primary power source outage.

**Rating Standard:** The Waukesha Enginotor power rating descriptions are in accordance to ISO 8528, DIN6271 and BS5514. It is also valid for ISO 3046/1-1986 with an engine mechanical efficiency of 90% and Tcra (clause 10.0) is limited to ± 10° F (5° C).

\*\*Heat rejection based on cooling exhaust gas to 77° F (25° C).

\*\*\* Requires option code 1100.

All natural gas engine ratings are based on a fuel of 900 Btu/ft³ (35.3 MJ/nm³) SLHV, with a 91 WK1®. For conditions or fuels other than standard, consult the Dresser Waukesha Application Engineering Department.

Cooling Equipment	L in (mm)	W in (mm)	H in (mm)	Avg. Wt. lb (kg)
Heat Exchanger	157 (3990)	57 (1450)	96 (2440)	17000 (7720)
Water Cooler	137 (3480)	57 (1450)	89 (2260)	16000 (7260)
Radiator	188 (4780)	105 (2670)	124 (3150)	20500 (9300)

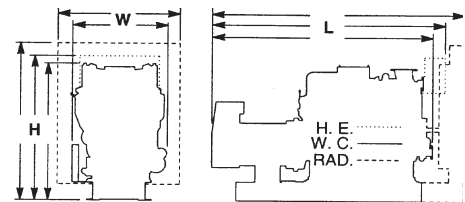

Consult your local Waukesha Distributor for system application assistance. The manufacturer reserves the right to change or modify without notice, the design or equipment specifications as herein set forth without incurring any obligation either with respect to equipment previously sold or in the process of construction except where otherwise specifically guaranteed by the manufacturer.

Bulletin 8071 1008

Dresser Waukesha  
1101 West St. Paul Avenue · Waukesha, WI 53188-4999  
Phone: (262) 547-3311 · Fax: (262) 549-2795

©2008 Dresser Inc. Waukesha, Enginotor, and VGF are trademarks/registered trademarks of Dresser Waukesha, Dresser, Inc.

**DRESSER® Waukesha**

www.dresser.com